

Stellplatz
Tiefgarage

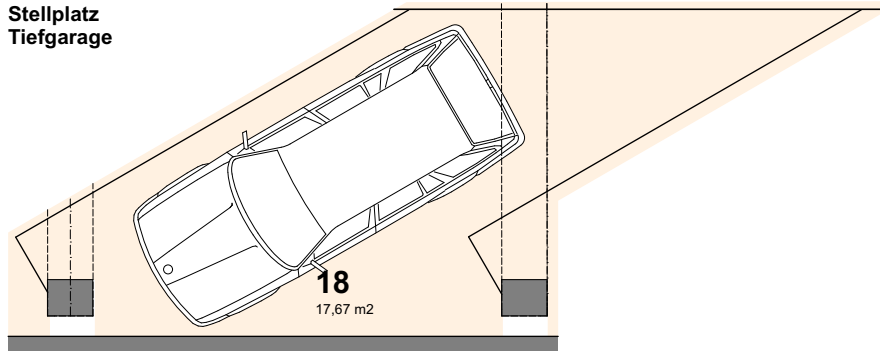

Volksgartenstraße 15
4020 Linz

TOP 37

5.OG

Treppe	1,61 m ²
Foyer	9,90 m ²
WC	1,74 m ²
Bad	6,63 m ²
Küche	8,46 m ²
WohEssZ.	31,94 m ²
Zimmer	14,58 m ²
Fitness	34,06 m ²
AR	4,66 m ²
Bad	3,64 m ²
WC	1,78 m ²
WNFL gesamt	119,00 m²
AR-37.2	5,03 m ²
AR-37.1	6,28 m ²
AR gesamt	11,31 m²
Terrasse	48,82 m ²
Terrassen ges.	48,82 m²

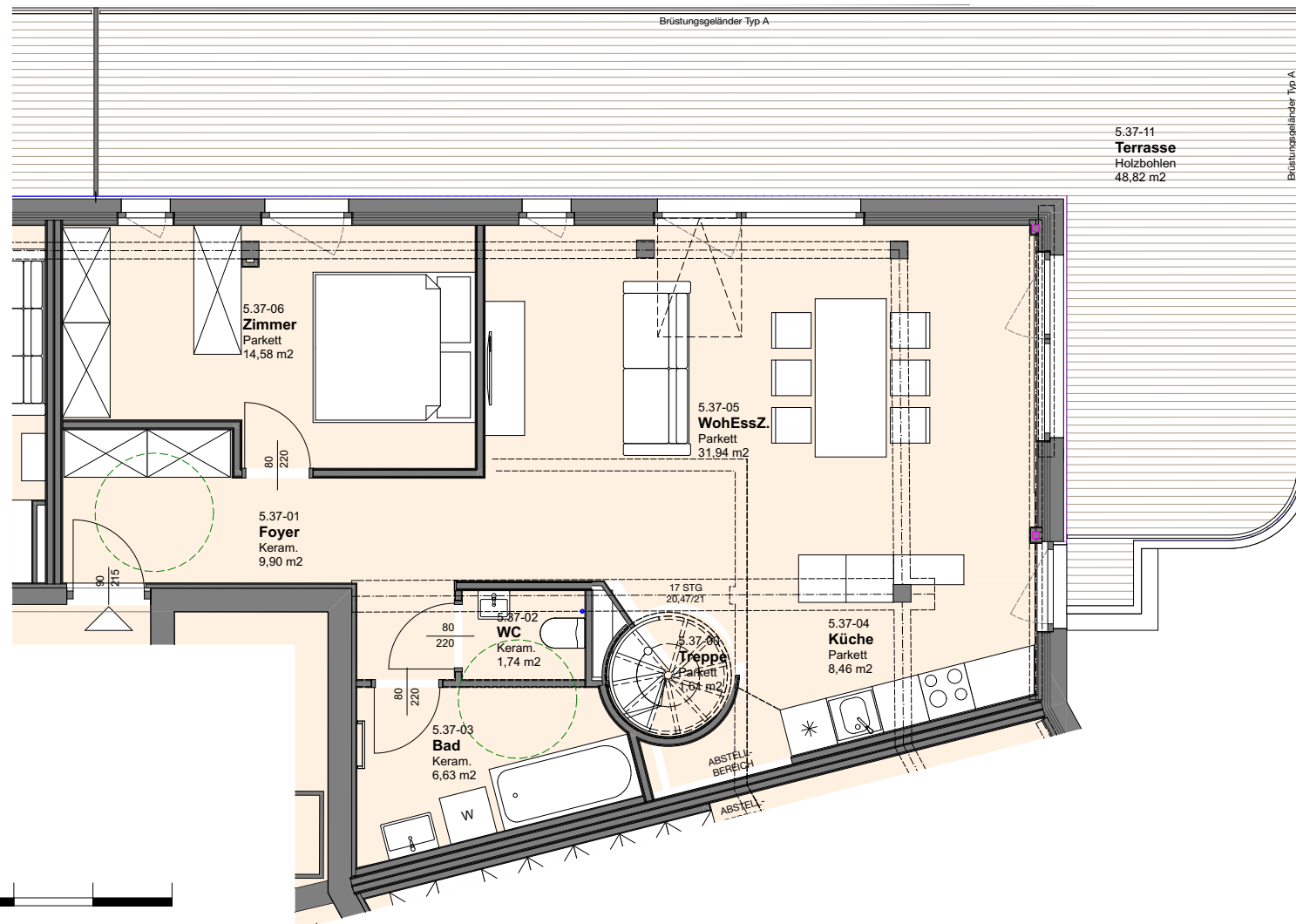

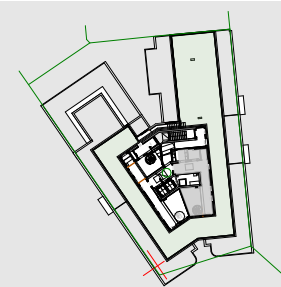

Volksgartenstraße 15
4020 Linz

TOP 37

Empore

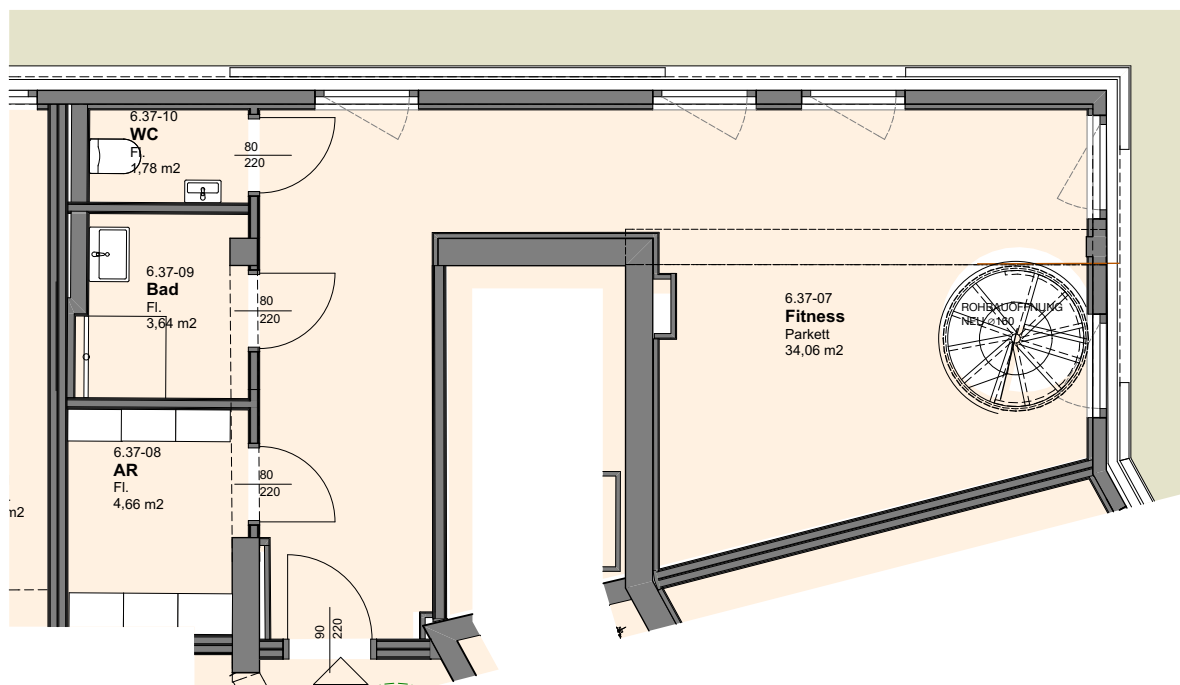

Unverbindliche Plankopie. Die Einrichtungsgegenstände dienen nur der Veranschaulichung und sind nicht Gegenstand des Vertrages, Flächenangaben beziehen sich auf Rohbaumaße.

